

**HSF RoHS**

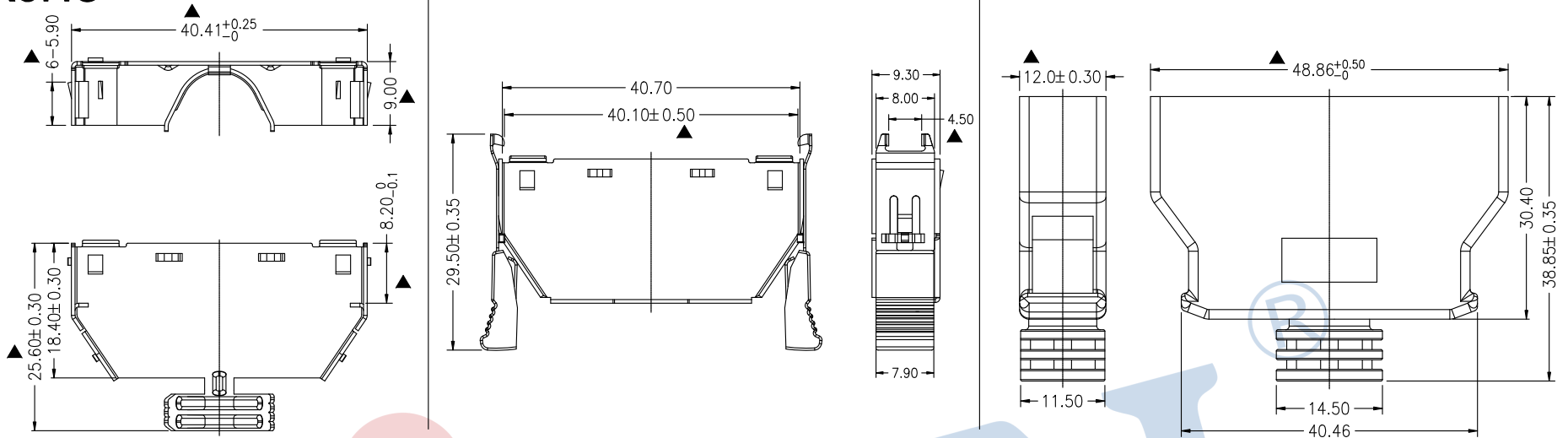

**Specification:**

- Contact Resistance: 35 m Ohm Max.
- Insulation Resistance: 200 M Ohm Min. At 500V DC.
- Contact Current Rating: 1 Amp AC/DC
- Voltage Rating: 40V AC.
- Withstanding Voltage: 500V AC For 1 Minute.
- Operating Temperature:  $-25^{\circ}\text{C}$  to  $+85^{\circ}\text{C}$
- Packing: Tray
- Control Dimensions Indicated From "▲".

**Material and Finish:**

- Insulator Material: PBTUL94-V0,Black
- Cover Material: PBTUL94-V0,Black/White
- Hood Plastic Material: ABS,Black/White
- Bullon Plastic Material: ABS,Black/White
- Contact Material: Phosphor Bronze(C5191-EH)T=0.25
- Contact Area Plated: Gold 1~30u" Plated Over Nickel 50u"
- Solder Area Plated: Tin Plated(80u" min Lead Free)
- Up or Down Shell Material: SPCC T=0.50
- Up or Down Shell Plated: Nickel 80u" Plated Over Cu 50u"
- Connector Shell Material: SPCC T=0.50
- Connector Shell Plated: Gold 1~3u" Plated Over Cu 50u"
- Hook Spring Material: Stainless Steel T=0.30

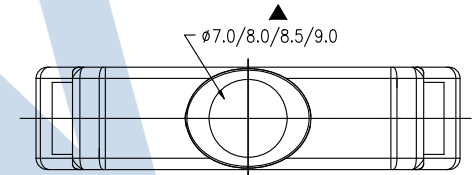
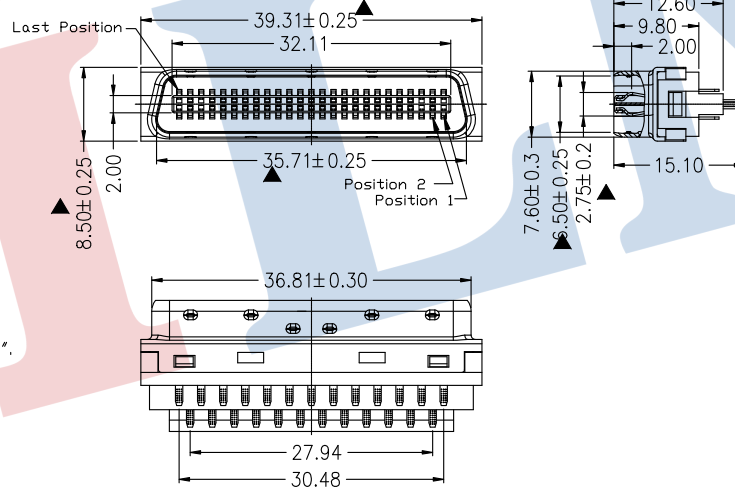

**Ordering Information**

**6320-M050 S D XX P N A 0 X**

No. of Pins  
14, 20P, 26P, 36P  
50P

Connector Type  
S= Straight

Contact Plating Stream Code  
G1: 1U" Gold  
G4: 3U" Gold  
G5: 5U" Gold  
S1: 1U" Gold / Tin  
S2: 3U" Gold / Tin  
S3: 5U" Gold / Tin

		OPERATION		DRAW	Jelly Feng	23.02.15	SCALE	FIT
		X.X	$\pm 0.30$					
		X.XX	$\pm 0.20$	CHECK				
		X.XXX	$\pm 0.10$					
		Angle	$\pm 3^{\circ}$	APPROVE				
		DIM	TOL					

**JILN**® 深圳市锦凌电子有限公司  
**SHENZHEN JINLING ELECTRONICS CO.,LTD**  
 Tel: 86-755-27483253 Fax: 86-755-2997-5588

REV	DATE	MODIFICATION DESCRIPTION	CHANGE
A0	2017.06.22	NEW DRAWING	

PART NO.	6320-M050SDXXPNA0X
TITLE:	HPCN 50P SCSI Solder-type Male